

Three-Phase Motor Protection

SubMonitor™ Three-Phase Protection



Applications

SubMonitor is designed to protect three-phase pumps by monitoring current, voltage and motor temperature* using three integrated current transformers. A face mounted digital display provides real-time current and voltage readings for all three legs and allows the user to set up the SubMonitor quickly and easily.

Protects Against

- Under/Overload
- Under/Overtoltage
- Current Unbalance
- Overheated Motor (Subtrol-equipped)
- False Start (Chattering)
- Phase Reversal

Features

- Quick, menu-driven set-up
- Digital display shows voltage and current on all three legs at once
- Fault messages in easily understandable text
- Rated for 190 to 600 volts
- No need for additional turns around the CT or to add external CTs
- Password protection option
- Din rail mounting option

- Stored fault, setting changes, and pump run-time information easily accessed through display head
- Detachable NEMA 3R display unit easily mounted on panel door
- Turn-and-push adjustment knob
- Base unit can operate independent of detachable head
- UL and cUL listed

Three-Phase Electronic Protection Device Specifications

Input Voltage	190 – 600 VAC
Frequency	60/50 Hz
Motor Service Factor Amps	5 to 350 Amps
Maximum Conductor Size Through Sensors	
Max Diameter	0.920 in. (23 mm)
Trip Response	
Motor Under/Overload, Under/Overtoltage, Overheat, Unbalance	3 seconds
Control Circuit Rating	1.5 Amp AC, up to 600 V

Signal Circuit Rating	1 Amp AC, up to 250 V
Wiring Terminals	
Wire Gauge	#12 to #18 AWG
Tighten to	4.5 in-lbs
Weight (SubMonitor)	3.3 lbs/1.5 kg
Carton Size (Std. Unit)	7.75 in x 11.5 in x 6.75 in (19.7 cm x 29.2 cm x 17.1 cm)
Shipping Weight (Std. Unit)	3.5 lbs/1.5 kg
Agency Approval	UL and cUL listed

* For motors equipped with a Subtrol heat sensor

Three-Phase Motor Protection

SubMonitor™ Three-Phase Protection

Models

PRODUCT	DESCRIPTION				MODEL	STOCK STATUS
	PH	MAX AMPS RANGE	VOLTS	HZ		
SubMonitor Standard	3	5 - 350	190 - 600	60/50	586 000 5000	YES
SubMonitor Premium*	3	5 - 350	190 - 600	60/50	586 000 5100	YES
Display	N/A	N/A	N/A	N/A	225 190 902	YES
Base Only	N/A	N/A	N/A	N/A	225 210 902	YES

* Includes lightning arrester and 3-year warranty on SubMonitor and Subtrol-equipped motor

Dimensions and Weights

SHIPPING WEIGHT		MOTOR CARTON SIZE (in inches)
LBS	KG	
3.3	1.5	7.75 x 11.5 x 6.75

Front Base Unit

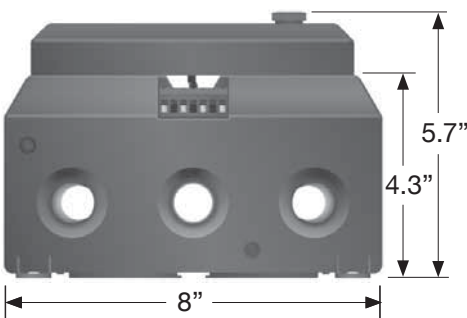

Detachable Display Unit



Top Base Unit

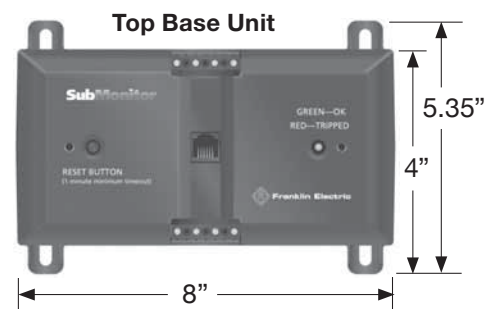

Display

- Real-time display of voltage and current for each leg.
- Easy menu-driven setup and adjustment of monitoring parameters.



SubMonitor Accessory



585 001 1100

D3 Data Download Tool

D3 is a service tool that provides the capability to download data from SubMonitor and transfer that data to a PC.

Includes:

- D3 unit
- Transfer software
- USB cable